



# JC6000 MULTI AXIS JOYSTICK CONTROLLER

# INNOVATION IN MOTION

The JC6000 rugged joystick controller is designed for demanding operator control applications in off-highway vehicles and other man-machine interfaces, where strength, reliability, and handle functionality are important. Available in one or two axis configurations, this joystick can be supplied with non-contact Hall effect sensors or long life potentiometer tracks. The JC6000's compact size, high lever strength and superb proportional control are ideal for applications which include operator controls on a wide range of off-highway vehicles, including cranes, loaders, excavators, access platforms, tractors and harvesters.

## Handles and grips

The JC6000 can be specified with a choice of handles and grips to increase the functionality of the operator controls. With a choice of push buttons, trigger grips, proportional and switched rockers in a variety of different configurations, users can match their handle selection to suit their unique application.



## Innovative design

With a choice of Hall effect sensors or potentiometer tracks to provide the analogue signals proportional to lever movement, the JC6000 can be configured to provide a range of output signals, directional and center switching functions, lever forces, and handle styles. CAN output can also be specified on the Hall sensor version for digital communication with vehicle systems.

### Features

- Hall effect or potentiometric sensing
  - Single or dual axis control
- High strength lever with superb proportional control
  - Sealed above the panel to IP66
  - Choice of outputs and switches
- Choice of handles/grips with or without switches
  - AMP 040 series multi-lock connectors
- Interchangeable with Penny + Giles' JC600 model

### Benefits

- Long life and maintenance-free operation
- Suited to a range of operator control functions
- Rugged and smooth lever movement
- Operation in hostile environments
- Enables user configuration for system safety
- Additional operator control functions
- Simple installation
- Improved performance within the same footprint



#### Quality Assurance

Penny + Giles are accredited to BS EN ISO9001:2000. Quality is at the heart of all our systems ensuring the reliability of our products from initial design to final despatch.

Certificate No.LRQ 0924881

# JC6000 MULTI-AXIS JOYSTICK CONTROLLER

## **Total reliability**

The JC6000 includes lever mechanics designed to give smooth proportional control, with Hall effect sensors that provide contactless, long life operation up to 15 million operations. Alternative potentiometer tracks featuring multi-fingered precious metal wipers give low electrical noise and a long life of greater than 5 million operations.



## **Safety**

The JC6000 with the Hall sensors option has dual outputs fitted as standard, allowing the signals to be monitored and compared for failure detection in safety critical applications. Additional independent switch functions can be specified for directional and center position indication - vital for vehicle system start-up safety. These switch functions are also available with the potentiometer tracks, which can also be specified with padding resistors to limit the output signals to 10-90% or 25-75%, allowing comparison and error detection.



## **Custom design**

Penny+Giles offer an extensive range of fingertip and hand operated joysticks in standard modular configurations, designed to meet the majority of individual customer needs, but we can customise our designs for OEMs who require something more specialised to their application. Please talk to our technical sales team about your requirements.

## **Cell manufactured**

The modular design of the JC6000 joystick is designed to provide the user with a wide choice of options, but allows efficient build and despatch using cell manufacturing principles. Contact your nearest sales office for the latest information on availability.



# JC6000 JOYSTICK CONTROLLER

## PERFORMANCE

### MECHANICAL

<b>Lever operating force breakout*</b>	<b>N</b>	4.7, 7 or 16
<b>operating*</b>	<b>N</b>	11.5, 19 or 39 (full deflection)
<b>maximum allowable**</b>	<b>N</b>	390 (490 overload)
<b>Lever mechanical angle single axis only</b>	<b>°</b>	±20 forward/reverse
<b>square gate</b>	<b>°</b>	±20 in X and Y directions
<b>Seat</b>		preferred bias on axis
<b>Expected life</b>		15 million operations (5 million for potentiometer track version)
<b>Weight</b>	<b>g</b>	750 without handle fitted

\* Measured at 55mm above upper flange face \*\* Measured 130mm above upper flange face

### ENVIRONMENTAL

<b>Operating temperature</b>	<b>°C</b>	-40 to +80 (-25 to +80 with microswitches)
<b>Storage temperature</b>	<b>°C</b>	-40 to +85 (-25 to +85 with microswitches)
<b>Environmental protection (above the flange)</b>		IP66 IEC 60529 (fitted with HKN handle)
<b>Vibration</b>		Level±3g,10Hz to 200Hz (random) @ 3.6g(rms)
<b>Shock</b>		20g, 6mS, half sine profile
<b>EMC immunity level</b>		100V/m, 30MHz to 1GHz, 1KHz 80% sine wave modulation, EN50082-2 (1995)
<b>EMC emissions level</b>		Complies with EN50081-2 (1993), 150kHz to 30MHz, level B
<b>ESD immunity level</b>		IEC61000-4-2 level 4 8kV contact discharge, 15kV air discharge

## ELECTRICAL - HALL EFFECT SENSOR

<b>Resolution</b>		Infinite
<b>Supply voltage range</b>	<b>Vdc</b>	5 ±0.5 regulated transient free
<b>Over voltage (maximum)</b>	<b>Vdc</b>	15 continuous
<b>Reverse polarity (maximum)</b>	<b>Vdc</b>	14.5
<b>Output voltage span - options</b>	<b>Vdc</b>	±25% span - nominal 1.1 to 3.9 ±30% span - nominal 1.0 to 4.0 ±40% span - nominal 0.5 to 4.5
<b>Load impedance (minimum)</b>	<b>kΩ</b>	5
<b>Center voltage (no load)</b>	<b>%</b>	48 - 52 of supply voltage
<b>Current consumption</b>	<b>mA</b>	13 per axis (6.5 per sensor)
<b>Insulation resistance</b>		Greater than 50MΩ at 50Vdc
<b>Output sense</b>		The dual outputs rise together in the same direction, increasing with lever forward (and right), decreasing with lever backward (and left)
<b>Output matching</b>		See maximum output difference diagram below

## ELECTRICAL CONNECTIONS

**Mating 12 way connector and pins**  
**Mating 12 way harness**

All Hall sensor connections terminate in a 12-way AMP 040 series multi-lock connector in the joystick base. See page 8 for pin identities

SA48061 (AMP 040 12 way connector 174045-4; pins 175062-1)  
P49779 (connector, pins and 380mm long cable)

**Output difference between sensors 1 + 3 or sensors 2 + 4 (same axis) with Vs = 5V**

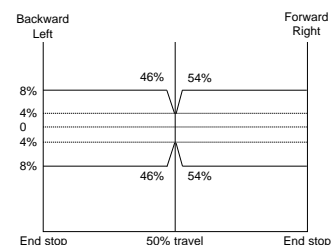

## ELECTRICAL - POTENTIOMETER TRACK

<b>Resolution</b>		Virtually infinite
<b>Track resistance ±20%</b>	<b>kΩ</b>	1.8, 2, 2.9, 5
<b>Track operating angle</b>	<b>°</b>	±18
<b>Output voltage range</b>	<b>%</b>	0-100, 10-90, 25-75 of input
<b>Center tap voltage</b>	<b>%</b>	48 - 52 of applied voltage
<b>Center tap angle</b>	<b>°</b>	±2.5
<b>Center tap to switch alignment</b>	<b>°</b>	Within 0.5
<b>Supply voltage maximum</b>	<b>Vdc</b>	32
<b>Wiper circuit impedance</b>	<b>MΩ</b>	1 minimum recommended*
<b>Power dissipation @ 25°C</b>	<b>W</b>	0.25
<b>Insulation resistance</b>		Greater than 50MΩ at 50Vdc

\* The long life resistive elements require a high impedance load in the wiper circuit to minimise the current flowing through the wiper for optimum life conditions

## ELECTRICAL - DIRECTIONAL OR CENTER SWITCH (LOW CURRENT)

<b>Switch operating angle</b>	<b>°</b>	Not available with CANbus output 1.5 or 5 either side of center
<b>Supply voltage maximum</b>	<b>Vdc</b>	35
<b>Load current maximum</b>	<b>mA</b>	200 resistive

## ELECTRICAL CONNECTIONS

**Mating 16 way connector and pins**  
**Mating 16 way harness**  
**Mating 8 way connector and pins**  
**Mating 8 way harness**

All primary potentiometer track and directional/center switch connections terminate in a 16-way AMP 040 series multi-lock connector in the joystick base. Secondary potentiometer track connections terminate in an 8-way AMP 040 series multi-lock connector. See page 8 for pin identities

SA47931 (AMP 040 16 way connector 174046-2; Pins 175062-1)  
P49780 (connector, pins and 380mm long cable)  
SA304522 (AMP 040 8 way connector 174044-2; pins 175062-1)  
P303083 (connector, pins and 380mm long cable)

## ELECTRICAL - MICROSWITCH

<b>Switch configuration</b>		Not available with CANbus output Two switches per axis. Normally open at lever center position
<b>Switch operating angle</b>	<b>°</b>	2 to 5 either side of center
<b>Contact rating</b>		3A @125Vac, 2A @ 30Vdc
<b>Switch life minimum</b>		100,000 cycles, cycled at 1Hz, 1A and 12Vdc
<b>Operating temperature</b>	<b>°C</b>	-25 to +85

## ELECTRICAL CONNECTIONS

Microswitch connections in the potentiometer joystick will replace the low current directional/center switches in the 16-way AMP 040 series multi-lock connector in the joystick base. In the Hall sensor joystick, switches terminate in the 8-way connector. See Electrical Connections on page 8 for pin identities

## CAN OUTPUT VERSION

<b>Supply voltage range</b>	<b>Vdc</b>	JC6000 with Hall sensing option can also be supplied with an integrated CANBUS output offering the J1939 protocol. This CANBUS interface meets the requirements of IEC61508 SIL level 1 9 to 36
<b>CAN version</b>		CAN 2.0b
<b>Protocol</b>		J1939
<b>Under-panel sealing</b>		IP66 IEC60529

## ELECTRICAL CONNECTIONS

All connections terminate in the 6-way Deutsch DTM04-6P integrated connector

# JC6000 JOYSTICK CONTROLLER

## HOW TO SPECIFY

### PERFORMANCE OPTIONS

### CODE

#### AXES

Single  
Dual

**NY**  
**XY**

#### SENSING

##### Output

**Potentiometer P<sub>x</sub>** or **P<sub>xx</sub>** selected from below

5k 0-100%, ±5° directional switch  
1.8k 0-100%, ±5° directional switch  
2.9k 25-75%, ±1.5° directional switch  
2k 10-90%, ±1.5° directional switch  
2k 10-90%, ±5° directional switch  
2.9k 25-75%, ±5° directional switch  
Dual outputs per axis, 2k 10-90%, ±1.5° directional switch

**P**  
**E**  
**N**  
**Q**  
**R**  
**S**  
**T**  
**U**

##### Output

**Dual Hall Effect** sensors each axis **H<sub>xx</sub>** with output selected from below  
**Dual Hall Effect** sensors each axis and ±1.5° directional switch **B<sub>xx</sub>** with output selected from below  
1.1Vdc to 3.9Vdc  
1.0Vdc to 4.0Vdc  
0.5Vdc to 4.5Vdc

**H**  
**B**  
  
**K**  
**L**  
**M**

##### CANbus Output

Single Axis/Dual Axis  
Note: Directional track switches not currently available with CANbus output.

**HC**  
**1 or 2**

#### LEVER SPRING FORCE

Heavy duty, 16N breakout, 39N full deflection  
Medium duty, 7N breakout, 19N full deflection  
Light duty, 4.7N breakout, 11.5N full deflection (Hall effect only)

**H**  
**M**  
**L**

#### GATE

Square ±20° mechanical angle in X and Y directions

**S**

#### MECHANICAL FEATURES

No lock or detents fitted

**NL**

#### MICROSWITCH

No switch fitted  
High current microswitches, 2A @ 30Vdc (Not available with CANbus output)

**N**  
**Y**

#### INTERFACE

Standard interface (no electronics)  
CANbus output, SAE J1939 protocol, Source Address 33 (HEX)  
1000 CAN counts Source Address 34  
Source Address 35  
Source Address 36

**STN**  
**JR1**  
**JL1**  
**JC1**  
**JA1**

#### HANDLE/GRIP STYLE

See pages 9-15

Standard knob, no functions  
Hand grip with options for buttons or rocker  
Ergonomic grip with multiple buttons and proportional rockers  
Trigger grip with optional rocker switching  
No handle  
No handle, flying leads fitted (allows customer to fit own handle.)

**HKN**  
**HB**  
**A**  
**MG**  
**NH**  
**NHF**

**EXAMPLE ORDER CODE** **JC6000 - XY - PRR - H - S - NL - N - STN - HKN**

# JC6000 JOYSTICK CONTROLLER

## DIMENSIONS

Note: drawings not to scale

## INSTALLATION

The joystick is designed to be fitted from below the mounting panel, through a 70mm diameter hole. The effectiveness of the joystick flange sealing is dependent on the panel mounting surface being sufficiently rigid to compress the sealing gaiter. The surface finish of the mounting panel is critical to achieving an adequate seal and rough surface finishes, paint chips, deep scratches, etc. should be avoided.

### Recommended panel thickness

3.5 to 6mm

### Recommended screw torque

Fixing screws can be driven to a maximum torque of 5Nm when clamped against a 3.5mm thick panel.

The mounting hole depth is 12.6mm. For through-hole installation, the screws can be driven at a torque of 3.5Nm directly through the blind cast holes to remove the cast covers. The joystick mounting flange should be connected to the vehicle chassis or reference plane (normally zero volts).

## POTENTIOMETER AND HALL EFFECT CONTROLLER

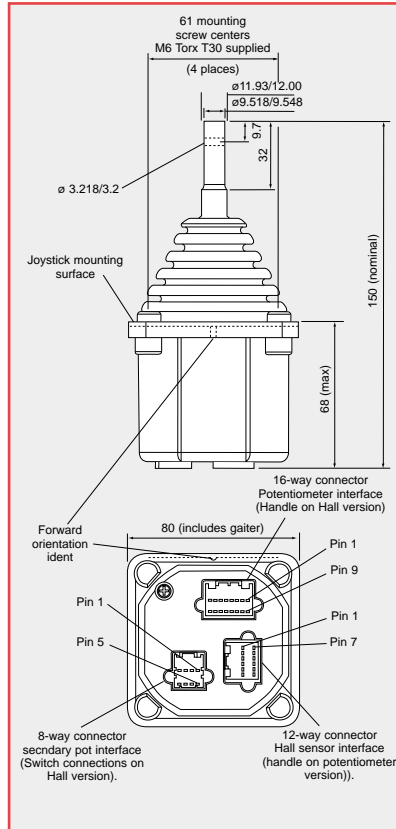

## CAN OUTPUT CONTROLLER

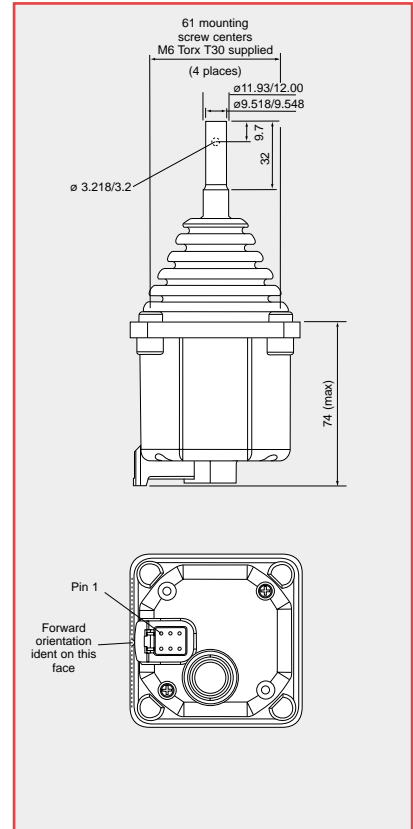

## CAN OUTPUT OPTIONS

The sealing of the lower cover meets the requirements of IP66 (IEC 60529) and uses an integrated Deutsch DTM04-6P 6 pin connector with the cover. The use of a suitable sealed mating connector will enable a full IP66 connection to be made. The cover also includes an integrated breather system to ensure pressure regulation under all barometric pressure and temperature conditions without moisture ingress into the joystick.

See next page for electrical connections

# JC6000 JOYSTICK CONTROLLER

## ELECTRICAL CONNECTIONS

	<b>Pin number</b>	<b>Potentiometer tracks</b>	<b>Hall effect sensors</b>
<b>16-way primary connector</b>	1	Y switch track N/O (lever forward +Y)	Pins 1 to 12 used for handle connections
	2	X switch track center on	See chosen handle style for details
	3	X pot track left	-
	4	X pot track wiper signal	-
	5	X pot track right	-
	6	X pot track center tap	-
	7	X switch track common	-
	8	X switch track N/O (lever left -X)	-
	9	Y pot track backward	-
	10	Y pot track wiper signal	-
	11	Y pot track forward	-
	12	Y pot track center tap	-
	13	Y switch track common	Not connected
	14	Y switch track N/O (lever backward -Y)	Not connected
	15	X switch track N/O (lever right +X)	Not connected
	16	Y switch track center on	Not connected
<b>8-way secondary connector (where fitted)</b>	1	Secondary Y pot track forward	Forward (directional or micro) switch common
	2	Secondary Y pot track center tap	Forward switch output
	3	Secondary Y pot track wiper signal	Backward switch output
	4	Secondary Y pot track backward	Backward switch common
	5	Secondary X pot track right	Left switch common
	6	Secondary X pot track wiper signal	Left switch output
	7	Secondary X pot track center tap	Right switch output
	8	Secondary X pot track left	Right switch common
<b>12-way connector</b>	1	Pins 1 to 12 used for handle connections	+5V supply - sensors 3 and 4
	2	See chosen handle style for connection details	0V supply - sensors 3 and 4
	3	-	+5V supply - sensors 1 and 2
	4	-	0V supply - sensors 1 and 2
	5	-	Forward/backward output - sensor 3
	6	-	Left/right output - sensor 2
	7	-	Left/right output - sensor 4
	8	-	Forward/backward output - sensor 1
	9	-	Not connected
	10	-	Not connected
	11	-	Not connected
	12	-	Not connected
<b>6 pin Deutsch connector CAN output</b>	1	Not available	Ground
	2	Not available	Power
	3	Not available	CAN high
	4	Not available	CAN low
	5	Not available	CAN shield
	6	Not available	Not connected

# JC6000 JOYSTICK CONTROLLER HANDLE OPTIONS



## HKN

The HKN handle is the simplest option available for the JC6000. This handle does not include any additional functionality, but is designed to allow the joystick to be controlled by the operator gripping the handle palm downwards.

## NH or NHF

These options are selected when no handle is required to be fitted. NHF option has wires fitted to the joystick connector on the base, through the operating lever.

## HB

Developed to replicate the functionality of the traditional mechanical handle, the HB range of hand grips can be specified with either a button or rocker switch, mounted into the top of the handle, within easy reach of the operator's thumb. These can be configured as a 'Person Present' feature or, for example, the steer signal for an access platform.



## A RANGE

Designed to meet the demands for more complex control systems in off-highway applications, the 'A' range of ergonomic hand grips can be fitted with a combination of analogue outputs, push button and 'Person Present' switches. The handle can be specified with two independent analogue outputs generated by proportional rockers which, in turn, provide auxiliary directional switching in addition to the potentiometric output. When coupled with the two axis JC6000 base joystick this unit can provide a four-axis controller.

This handle can also be purchased separately, for fitting to customer levers or assemblies. Ask our sales team for more details on this option.

## MG

Designed to provide a simple approach to a 'Person Present' handle whilst offering the flexibility of switch options in the top of the handle. The profile of the MG handle ensures the operator's fingers are permanently close to the buttons, minimising operator fatigue and maximising functional control. The handle can be supplied with or without a hand rest and can be configured with a combination of trigger lever, single or dual switches.

This handle can also be purchased separately, for fitting to customer levers or assemblies. Ask our sales team for more details on this option.



# HKN HANDLE OPTION

## DIMENSIONS

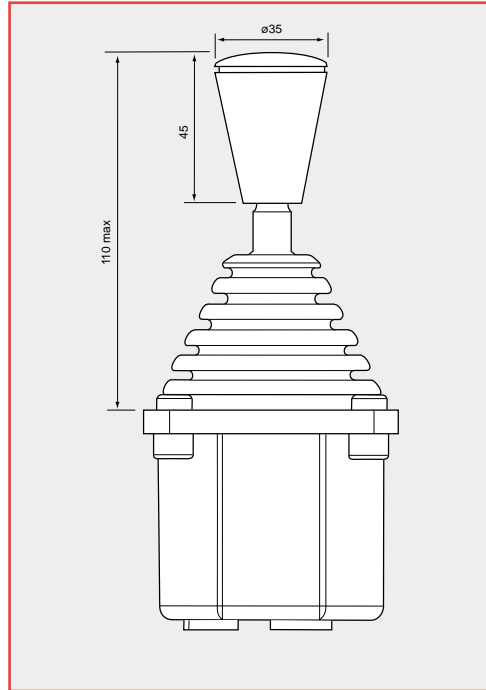

# NH OR NHF HANDLE OPTIONS

## ELECTRICAL CONNECTIONS

**Wire size**  
**Wire current**

28AWG  
1.4A

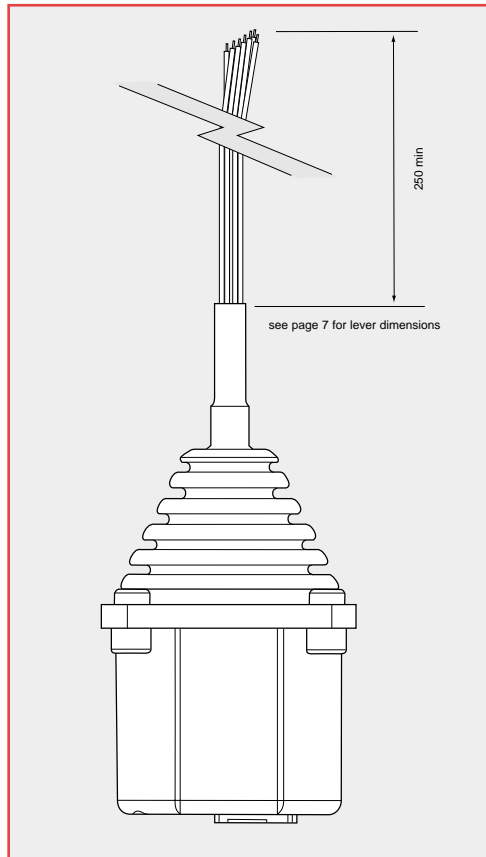

NH option has no wires fitted.  
NHF option allows customer to fit own handle style to joystick operating lever.

Pin	Wire color
1	Grey
2	Yellow
3	Red
4	Orange
5	Brown
6	Black
7	Green
8	White
9	Blue
10	Violet
11	Pink
12	Red/Yellow
13	Not connected
14	Not connected
15	Not connected
16	Not connected

NHF handle option note: Wires terminate on the 12-way connector (Potentiometer version), or the 16-way connector (Hall sensor version).

# HB HANDLE OPTIONS

## DIMENSIONS

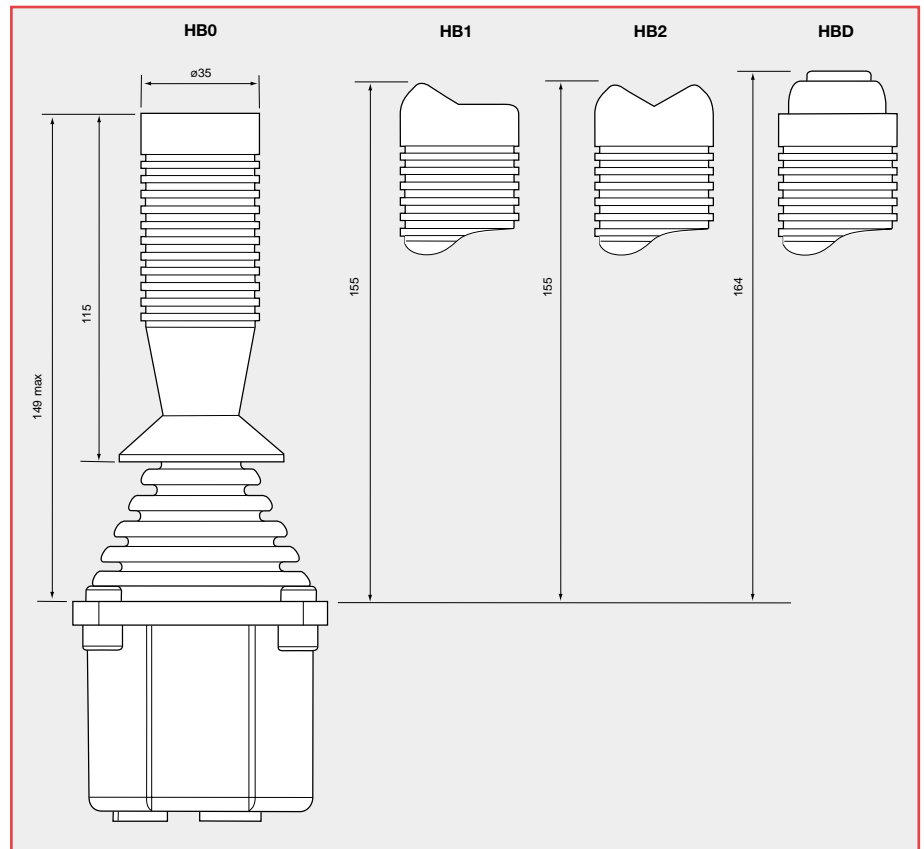

## SPECIFICATION

		<b>H B 0</b>	<b>H B 1</b>	<b>H B 2</b>	<b>H B D</b>
<b>Maximum height above flange</b>	<b>mm</b>	149	155	155	164
<b>Maximum grip diameter</b>	<b>mm</b>	35	35	35	35
<b>Environmental sealing (IEC 60529)</b>		IP65	IP65	IP65	IP65
<b>Number of switches</b>		0	1	2	1
<b>Action</b>			Momentary rocker	Momentary rocker	Momentary button
<b>Switch operating force</b>	<b>N</b>	-	-	-	7
<b>Maximum current @ 30Vdc</b>	<b>A</b>	-	2.5	2.5	5
<b>Expected life (operations)</b>		100,000	100,000	100,000	100,000

## ELECTRICAL CONNECTIONS

<b>Common terminal</b>		11	11	11
<b>N/O contact switch 1</b>		4	4	1
<b>N/C contact switch 1</b>		1		
<b>N/O contact switch 2</b>			1	

Note: Signals terminate on the 12 way connector (potentiometer version) or the 16 way connector (Hall sensor version)

# A RANGE HANDLE OPTIONS

## SPECIFICATION

<b>Maximum height above flange mm</b>	166
<b>Maximum grip diameter mm</b>	61
<b>Environmental sealing (IEC 60529)</b>	IP65
<b>Number of switches</b>	1 to 6 in the top plate
<b>Action</b>	Momentary button
<b>Switch operating force</b>	<b>N</b> 3
<b>Maximum current @ 50Vdc</b>	<b>mA</b> 200
<b>Expected life (operations)</b>	1 million
<b>Weight</b>	<b>g</b> 170 - A2LD option
<b>Operating temperature</b>	<b>°C</b> -40 to +70
<b>Storage temperature</b>	<b>°C</b> -40 to +80

## ROCKER

<b>Rocker profile</b>	Standard (S) or V profile (V)
<b>Breakout force</b>	<b>N</b> 5 at the end of the rocker
<b>Operating force</b>	<b>N</b> 15 at the end of the rocker
<b>Mechanical movement</b>	° ±10 (±1°)
<b>Electrical movement</b>	° ±9 (±1°)
<b>Expected life (operations)</b>	5 million
<b>Load current (maximum)</b>	<b>mA</b> 200 (see note on page 5)
<b>Power dissipation @ 25°C</b>	<b>W</b> 0.25
<b>Track resistance</b>	Will match JC6000 Y axis resistance †
<b>Output voltage</b>	Will match JC6000 Y axis output †
<b>Center tap angle</b>	° ±1.5
<b>Directional or center off switch</b>	Standard
<b>Switch gap</b>	° 2.5 either side of center
<b>Switch supply voltage</b>	<b>Vdc</b> 35

† unless requested otherwise

## FUNCTIONALITY

## SWITCHES

## ROCKERS

	1	2	3	4	5	6	TOP	Person Present	LEFT	RIGHT	HORIZONTAL
<b>SWITCH 1</b>	✓	✓	✓	✓	✓	✓	✓	✓	✓		
<b>SWITCH 2</b>	✓		✓	✓	✓	✓	✓	✓	✓		✓
<b>SWITCH 3</b>	✓	✓		✓	✓	✓	✓	✓		✓	✓
<b>SWITCH 4</b>	✓	✓	✓		✓	✓	✓	✓		✓	
<b>SWITCH 5</b>	✓	✓	✓	✓		✓	✓	✓		✓	
<b>SWITCH 6</b>	✓	✓	✓	✓	✓		✓	✓	✓		
<b>TOP SWITCH</b>	✓	✓	✓	✓	✓	✓		✓	✓	✓	
<b>PERSON PRESENT</b>	✓	✓	✓	✓	✓	✓	✓		✓	✓	✓
<b>LEFT ROCKER</b>	✓	✓				✓	✓	✓		✓	
<b>RIGHT ROCKER</b>			✓	✓	✓		✓	✓	✓		
<b>HORIZONTAL</b>		✓	✓				✓	✓			

## SWITCH AND ROCKER OPTIONS

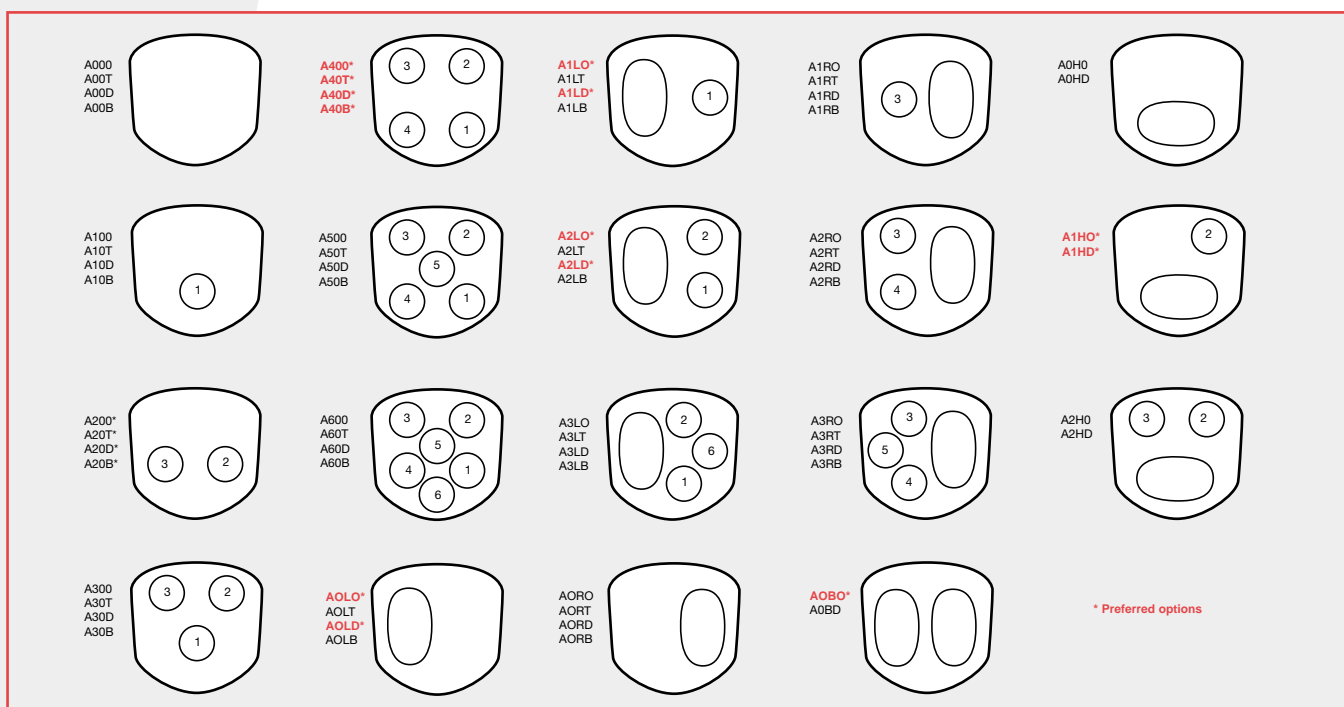

## DIMENSIONS

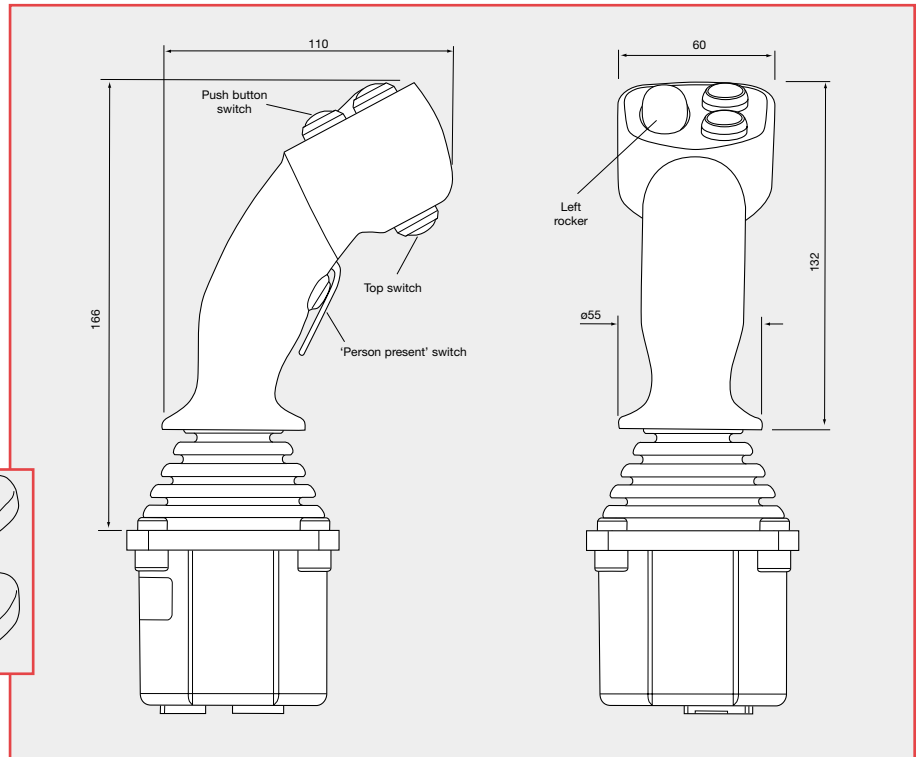
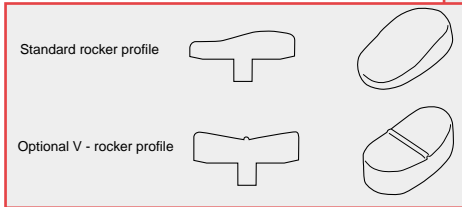

## ELECTRICAL CONNECTIONS

	<b>Pin</b>	<b>Wire color</b>		<b>Pin</b>	<b>Wire color</b>
<b>Common terminal (for all switches)</b>	11	Black	<b>Rocker positive supply (L, R or H)</b>	7	White/Red
<b>Switch 1</b>	4	Blue	<b>Rocker center tap</b>	6	Yellow/Red*
<b>Switch 2</b>	3	Yellow	<b>Rocker zero or negative supply (L, R or H)</b>	10	Pink/Grey
<b>Switch 3</b>	2	Blue/Orange	<b>Rocker output signal (L or H)</b>	5	Pink
<b>Switch 4</b>	1	Green	<b>Rocker output signal (R)</b>	9	White
<b>Switch 5</b>	†	Red	<b>Rocker switch common</b>	11	n/a
<b>Switch 6</b>	†	Violet	<b>Rocker switch (L forward)</b>	2	Blue/Orange
<b>Top switch</b>	†	Pink with marker	<b>Rocker switch (L backward)</b>	1	Green
<b>Person present switch</b>	12	Red/Green	<b>Rocker switch (R forward)</b>	3	Yellow
<b>Person present switch</b>	8	Black/White	<b>Rocker switch (R backward)</b>	4	Blue
			<b>Rocker switch (H left)</b>	4	Blue
			<b>Rocker switch (H right)</b>	1	Green

† depends on other options selected

\*Center tap not connected on A3LB and A3RB handles

Note: Signals terminate on the 12-way connector (Potentiometer version), or the 16-way connector (Hall sensor version)

## ORDERING CODES

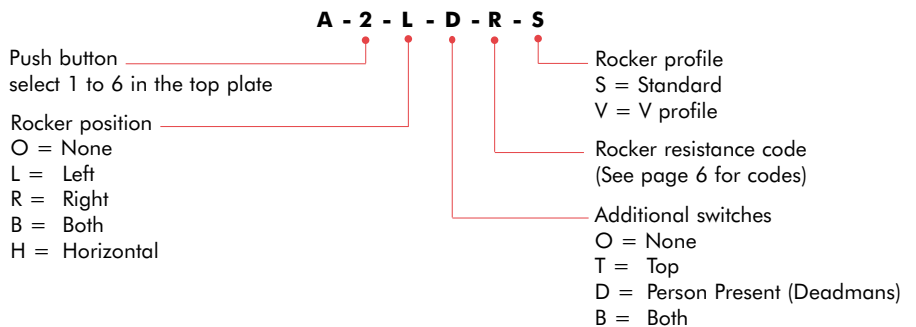

Note: When ordering a handle fitted with a rocker, two profiles can be supplied (S = standard profile; V = v profile) please specify style when ordering.

# MG HANDLE OPTIONS

## DIMENSIONS

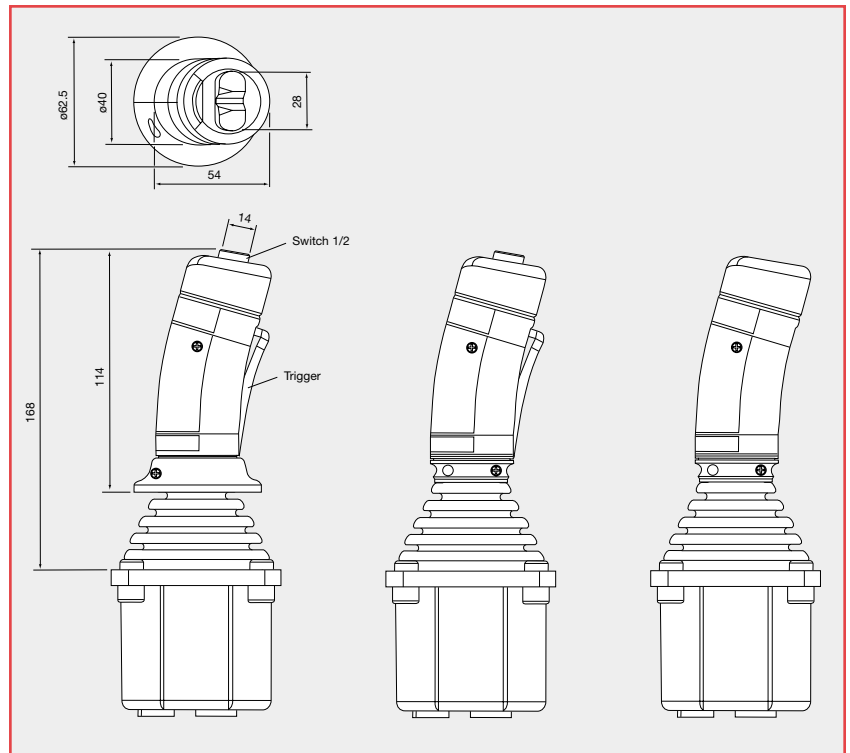

## SPECIFICATION

<b>Maximum height above flange</b>	<b>mm</b>	168
<b>Maximum grip diameter</b>	<b>mm</b>	40
<b>Environmental sealing (IEC 60529)</b>		IP67 (IP66 with trigger switch)
<b>Number of switches</b>		0 to 3
<b>Action</b>		Momentary Button, Rocker or Trigger
<b>Switch operating force</b>		
<b>Trigger</b>	<b>N</b>	5
<b>Switch 1 or 2</b>	<b>N</b>	7
<b>Maximum current @ 30Vdc</b>	<b>mA</b>	100
<b>Expected life (operations)</b>		1 million
<b>Operating temperature</b>	<b>°C</b>	-25 to +75
<b>Storage temperature</b>	<b>°C</b>	-30 to +80

**HANDLE CODE**

	<b>Top switch position</b>	<b>Trigger switch</b>	<b>Hand rest</b>
<b>MG00</b>	None	No	No
<b>MG01</b>	1	No	No
<b>MG02</b>	1 & 2	No	No
<b>MG03</b>	1 & 2	Yes	No
<b>MG04</b>	1 & 2	Yes	Yes
<b>MG05</b>	1	Yes	Yes
<b>MG06</b>	1 & 2	No	Yes
<b>MG07</b>	1	No	Yes
<b>MG08</b>	1	Yes	No
<b>MG09</b>	None	Yes	Yes
<b>MG10</b>	None	None	Yes
<b>MG11</b>	None	Yes	No

See Termination details for wire color codes.

**ELECTRICAL CONNECTIONS**

	<b>Pin number</b>	<b>Wire color</b>
<b>Common terminal (for top switches)</b>	12	Black
<b>Switch 1</b>	6	Blue
<b>Switch 2</b>	3	Green
<b>Trigger switch</b>	4	Blue/Orange
<b>Trigger switch</b>	5	Yellow

Note: Signals terminate on the 12-way connector (Potentiometer version), or the 16-way connector (Hall sensor version)



[www.pennyandgiles.com](http://www.pennyandgiles.com)

**Penny & Giles**

Position sensors and joysticks for commercial and industrial applications.

15 Airfield Road  
Christchurch  
Dorset BH23 3TG  
United Kingdom  
+44 (0) 1202 409409  
+44 (0) 1202 409475 Fax  
sales@pennyandgiles.com

36 Nine Mile Point Industrial Estate  
Cwmfelinfach  
Gwent NP11 7HZ  
United Kingdom  
+44 (0) 1495 202000  
+44 (0) 1495 202006 Fax  
sales@pennyandgiles.com

5875 Obispo Avenue  
Long Beach CA 90805  
USA  
+1 562 531 6500  
+1 562 531 4020 Fax  
us.sales@pennyandgiles.com

Straussenlettenstr. 7b  
85053 Ingolstadt,  
Germany  
+49 (0) 841 61000  
+49 (0) 841 61300 Fax  
info@penny-giles.de

The information contained in this brochure on product applications should be used by customers for guidance only. Penny+Giles Controls Ltd makes no warranty or representation in respect of product fitness or suitability for any particular design application, environment, or otherwise, except as may subsequently be agreed in a contract for the sale and purchase of products. Customer's should therefore satisfy themselves of the actual performance requirements and subsequently the products suitability for any particular design application and the environment in which the product is to be used.

Continual research and development may require change to products and specification without prior notification. All trademarks acknowledged.

© Penny+Giles Controls Ltd 2006

Innovation In Motion

**CURTISS**  
**WRIGHT** Controls  
Integrated Sensing

[www.cwcontrols.com](http://www.cwcontrols.com)